

The Wembley sour gas plant operated by ConocoPhillips is located near Grande Prairie, Alberta, Canada. It processes a wide range of raw gases containing negligible quantities of H₂S and CO₂ with concentrations as high as 10% acid gas. The method employed to remove these undesirable components is via contacting the inlet gas with an aqueous alkanolamine solvent. In this process, the raw inlet gas mixes with the solution, causing the acid gas components to react with the amine, which forms a regenerable salt in the aqueous phase. This process is the most widely utilised throughout the industry for sweetening sour natural gas¹.

The amine solution is regenerated by adding heat at low pressure in the amine regenerator. Rich amine solution enters the top of a trayed regenerator column and at the bottom of this tower there is a reboiler that supplies heat to the system. As the solution flows down the vessel it heats up, causing the acid gases to disassociate from the amine and the water to vaporise. The solution that reaches the bottom of the amine regenerator has essentially had all of the acid gases removed. The lean bottom solution is cooled and recycled to treat additional incoming raw gas.

The acid gas flow from the top of the amine regenerator consists primarily of a water saturated stream of CO₂ and H₂S. As this stream is cooled in the overhead air exchanger some of the water condenses and is recovered by refluxing to the column via the reflux drum. At this point in an alkanolamines process, there are several options for dealing with the residual H₂S/CO₂ components that have been removed from the raw sour gas. The method utilised at the Wembley gas plant is to reinject this acid gas back into a well that has been completed to allow for safe disposal. This method ensures that there is no H₂S, SO₂ or CO₂ released into the atmosphere and does not require stockpiling of sulfur onsite.

Acid gas injection process overview

The Wembley gas plant typically produces 60 - 100 e³m³/d (1000s of m³/d) of acid gas from two separate amine regeneration towers. Composition of the gas has a large amount of day to day variation depending on the particular wells being processed through the plant and also on the degree of CO₂ slippage occurring in the amine contactors. The ratio of H₂S to CO₂ ranges between 40:60 - 85:15. In addition to the acid gas components, the stream is water saturated at the amine regeneration overhead process conditions, typically 45 °C and approximately 35 kPag. It also contains some hydrocarbons, mainly methane, due to small amounts of these components being dissolved in the aqueous amine solution as it flows through the contactor. These hydrocarbons are liberated in the amine regenerator and generally amount to less than 1% of the overhead flow.

Since the acid gas coming from the regenerator is only slightly above atmospheric, six stages of compression are required in order to boost the pressure to the appropriate range between 10 000 - 20 000 kPag so it can be disposed of into the injection well. The acid gas compressor consists of a single frame containing six throws. Two of the throws are utilised for the first stage to account for the large volumes at low suction pressures, while the fifth and sixth stages are located on the head end/crank end of a single throw. There is a suction scrubber located before the first stage to knock out any liquid water formed due to cooling in the piping between the regeneration units and the compressor. Each interstage contains a cooling section followed by a suction scrubber prior to the subsequent stage of compression. Suction scrubbers for the first four stages of compression dump back to a low pressure sour water tank, while the fifth and sixth stage scrubber dumps flow to

Enhancing operations

J. R. Sitter, ConocoPhillips, Canada,
G. Hay, Virtual Materials Group, Canada,
and L. Neumeister, Spartan Controls Ltd,
Canada, explain how an online model
can be used to enhance the operation of
acid gas injection schemes.



Figure 1. Wembley gas plant.

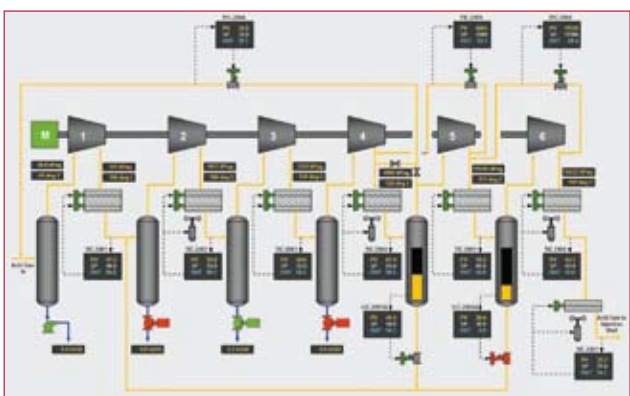

Figure 2. Acid gas compressor process flow.

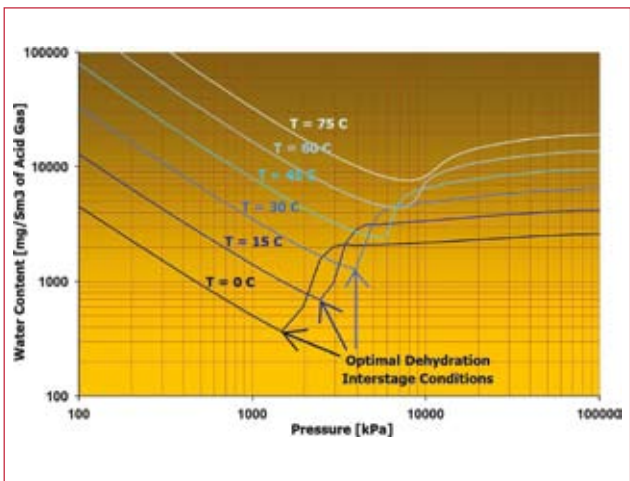

Figure 3. Water content of acid gas containing 49% H_2S , 49% CO_2 , 2% CH_4 .

the second stage scrubber. Capacity control for the system is accomplished via a series of three recycles from fourth to first stage, fifth to fourth stage, and sixth to fifth stage. The use of multiple recycles is required due to the large pressure differentials across the system to prevent cryogenic conditions from occurring.

Acid gas dehydration by compression

Acid gas injection/disposal schemes generally require the acid gas be under saturated with water at the high injection pressures to prevent corrosion and hydrates from occurring. Due to the phase behaviour of these gases, it is feasible to dehydrate them through the compression stages without

using any external dehydration equipment, such as glycol contactors or mole sieves². In order to accomplish this, the water holding behaviour of CO_2 and H_2S must be understood. Whereas with a sweet natural gas, the water content will be progressively reduced at a fixed temperature with increasing gas pressure, this is not the case for CO_2 and H_2S . With sour gas mixtures, the saturated water content will initially be reduced with increasing pressure. However, a minimum can be reached and beyond this point the gas is actually able to hold more water with increasing pressure. This is illustrated in Figure 3, where the lines of fixed temperature illustrate the water content of a saturated acid gas over a range of pressures. The minimum saturated water contents would obviously represent the optimal points for interstage scrubber conditions since that would represent the lowest amount of water that the gas could contain without additional dehydration. As the gas is compressed beyond these pressures, it will become under saturated at a fixed temperature as it could in fact hold more water. This is the overriding concept guiding the dehydration of acid gas using compression alone.

Understanding the process pathway

Clearly, from the above description, the lowest water content would be achieved if the temperature could be made as cold as possible at the appropriate pressure. However, this ability is restricted due to limitations imposed by the 'phase envelope' and hydrate curves for a given gas composition. Figure 4 illustrates the phase envelope concept. When a single phase gas is cooled, condensation will begin to occur when the dewpoint curve is intersected. Upon further cooling, additional vapour condenses until it is completely liquid at the bubble point. At even cooler temperatures, the fluid is a single phase liquid. The phase envelope is the region bounded by the dewpoint and bubble point curves. The curves meet at the critical point, i.e. the critical temperature and pressure. A fluid that is at a pressure or temperature greater than the critical point value is considered a super critical fluid.

Figure 5 details the phase envelope and hydrate curves for a range of acid gas compositions. This Figure is also overlaid with the compression process pathway for typical acid gas injection operation at the Wembley plant. One of the main distinguishing features to note in the compression of acid gas is the presence of the phase envelope at ambient temperature conditions, versus a typical natural gas where phase envelope effects are not apparent until temperatures are well below $0^\circ C$.

From Figure 5 it is apparent that after the first three stages of compression the limitation for interstage cooling is generally reached as the temperature approaches the hydrate line. If the gas were cooled below this temperature there is a strong possibility that hydrates will form, since the gas will still be saturated with water. At higher H_2S to CO_2 ratios, it is also possible that the interstage cooling limitation for the third stage discharge may in fact be the gas dewpoint line. If the gas is cooled beyond the dewpoint, liquid acid gas will begin to accumulate in the fourth stage suction scrubber. This is a very hazardous situation, as the fourth stage scrubber dumps to a sour water tank that is maintained only slightly above atmospheric pressure. The presence of a liquid H_2S/CO_2 mixture in a low pressure environment will result in rapid expansion of the gas with a potential for tank overpressure and/or release of harmful H_2S into the atmosphere. Comparing Figure 3 and Figure 5 would lead one to rightfully conclude that for the Wembley compression pathway, the temperature in the fourth stage suction ultimately determines the water content in the final

discharge. This is due to the fact that the range of pressures where the minimum water content is typically found is near the conditions exhibited at this point in the process.

The limitation for cooling the fourth stage discharge gas is almost exclusively dictated by the acid gas phase envelope characteristics. Overcooling below the dewpoint line in this intercooler will result in either partial or complete condensation of the acid gas. To account for the fact that any liquids formed are in fact liquefied acid gas, the scrubber dump line is directed back to the second stage scrubber vessel. The lower second stage suction pressure allows the liquefied acid gas to flash back into the vapour phase to be recompressed. Although this arrangement maintains containment of the CO₂ and H₂S within the process, it is somewhat inefficient as it results in an additional recycle through the compressor. If the gas is fully condensed in the fifth stage suction scrubber, the compressor will essentially be in full recycle.

After the fifth stage of compression, the phase envelope characteristics may require limitations on interstage cooling depending on whether or not the pressure is high enough to be above the critical point of the particular gas mixture being compressed. Current operation of the Wembley gas plant results in the sixth stage suction pressure almost always operating above 9500 kPa, which is above the critical point for any expected gas compositions. A result of operating in this super critical region is that there is no phase separation. To account for this, the sixth stage scrubber dump is manually shut in, regardless of whether the level controller senses a level or not.

Problems and challenges

As discussed above, the ability for acid gas to become undersaturated during compression is fairly well established. Attaining the optimal dehydration simply requires that the gas be maintained as cool as possible at the pressure range where the minimum water content would be expected to occur while taking into account limitations imposed by the phase envelope and hydrate formation. A heuristic approach to this process has been provided by Ed Wichert: If the pressure is in the range of 3000 - 4800 kPa and the gas is cooled to within 3 - 4 °C of its hydrate or dewpoint (whichever is greater), the gas will be undersaturated at a temperature of 0 °C with a final discharge pressures above 8000 kPa³. The problem lies in consistently achieving this mode of operation in an operating facility, and in accurately determining where the dewpoint and hydrate temperatures are located on a real time basis.

Particular problems experienced at the Wembley gas plant while operating its acid gas injection compressors include:

- Inconsistent/inefficient water dehydration after the final stage of compression.
- Liquefaction of acid gas in the fifth stage scrubber.
- Inconsistency and difficulty balancing flows across the compression system.

On the first two points, the problem lies mainly in the fact that the Wembley plant is subject to a high degree of day to day variability in its acid gas composition, leading to dynamic changes in both the water saturation and phase envelope characteristics. The standard operating approach taken in the past was to try to run the compressors in a consistent manner without regard for the actual gas composition, or a true appreciation of how the process was intended to achieve undersaturation. When the compressors are run in this style, i.e. by attempting to maintain similar interstage temperature and pressure conditions,

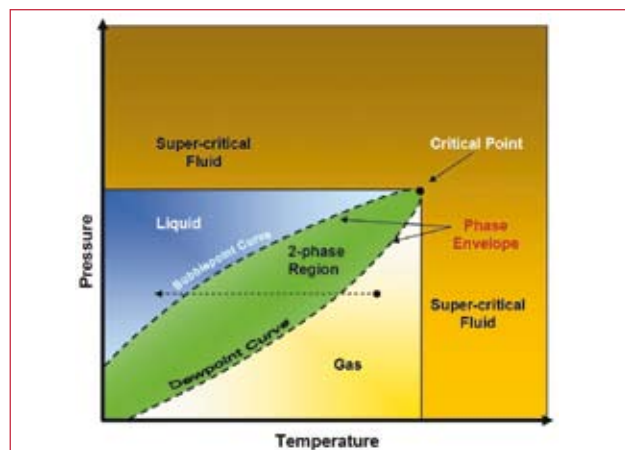

Figure 4. Phase envelope concept.

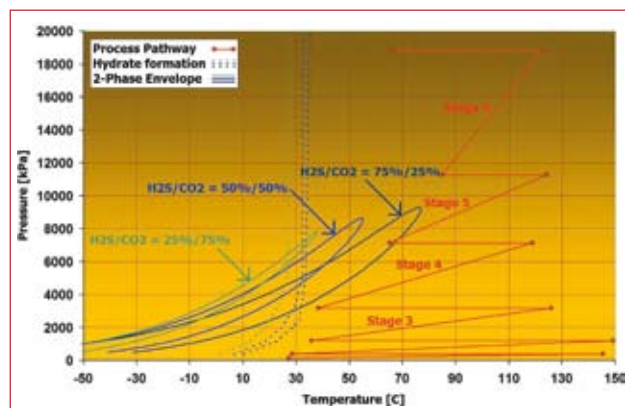

Figure 5. Process pathway with varying H₂S/CO₂ ratios (2% CH₄ balance).

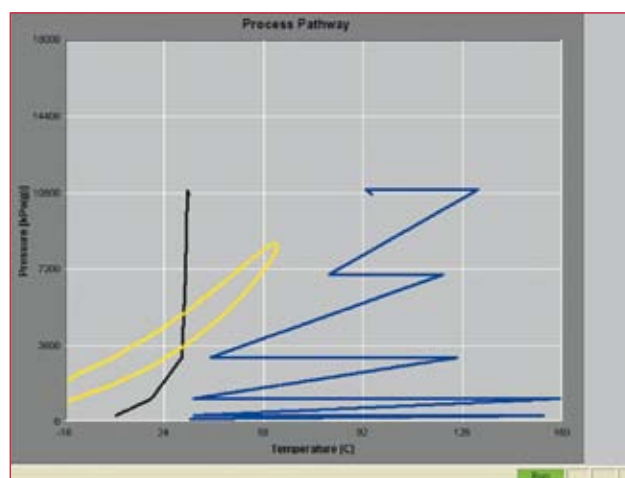

Figure 6. Phase envelope HMI graphic.

then clearly the degree of dehydration and the phase envelope interactions will change in response to the changes in the acid gas compositions. These variations may have potentially undesirable results.

In order to achieve consistent dehydration in the lower stages of compression and to avoid interaction with the dew point at the higher stages, there is a requirement to not only know and understand the phase properties, but also to be able to control the interstage temperatures in response to changes. From an operations point of view, this is typically a very difficult problem to intuitively understand or troubleshoot without proper data interpretation tools.

The third point relating to problems with measurement is also partially related to the variable compositions of gas processed through the Wembley gas plant. There

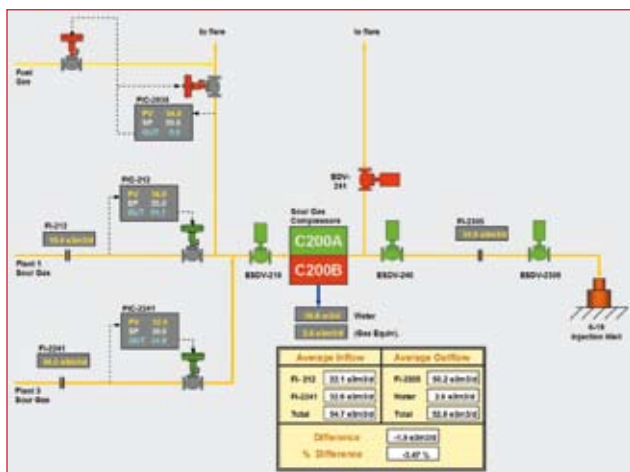

Figure 7. Acid gas material balance HMI graphic.

are three orifice type meters located around the compression system; one on each of the regeneration tower overheads, and a single meter located downstream the compressor discharge. Ideally, it would be possible to consistently balance the two inlet meters with the single outlet meters to achieve some degree of confidence in the measurement capability. However, at the Wembley gas plant this had not been the case. With the two low pressure meters located on the amine regeneration overheads, the AGA – 8 (1992) method should suffice for calculating the compressibility factor within $\pm 2\%$ for input into the orifice flow calculation⁴. The problem for these meters was that the calculation was not being updated with live results off the process gas chromatograph, hence introducing errors into the inlet gas flow calculation. In addition, since the gas analysis is completed on a dry basis, there must also be some estimate made of the water composition before a truly accurate determination of the flow can be made. On the low pressure acid gas, this water content can account for upwards of 5% of the overall gas composition.

The high pressure meter located downstream of the compressor train poses a more difficult challenge for the usual compressibility and density estimates because the fluid is well into the supercritical region. At this point it is recommended to use a calculated density from a reliable simulator as an input into the flow calculation, rather than relying on standard AGA measurement correlations⁵. Again, with varying compositions on the Wembley process, the problem is ensuring that the calculated density is continuously updated to account for these variations.

The final problem noted with accounting for inlet and outlet flows through the acid gas compressor was due to the fact that the scrubber dump flows are unmeasured and unaccounted for. In an acid gas compression system the water flow accounts for a significant portion of the flow into the compressor. If this flow is not accounted for out of the suction scrubbers, then the balance calculations could be out by as much as 5% or more.

Online modelling solution

It was proposed that the problems discussed above could be rectified by the addition of an online model integrated with the plant's distributed control system. An online model of the acid gas properties can be used to indicate the lowest operating temperatures without hydrates or liquids occurring in the lower stages, hence achieving the maximum amount of dehydration. In the later stages

of compression the model can be used to provide temperature requirements to avoid liquefying acid gas in the scrubbers. Since an online model would be routinely calculating fluid properties, it can be further leveraged to provide density or compressibility inputs into the measurement calculations. A properly functioning model is also capable of estimating the amount of water drop out in each of the scrubbers based on actual interstage process conditions.

The Virtual Materials Group process simulator (VMGSim™) was utilised as the model engine to provide the dry basis phase envelope/hydrate calculations, in addition to the acid gas water content predictions. A key prerequisite for the simulation package was the ability to be fully integrated within the existing plant DeltaV™ control system. There was also a requirement to provide customised human machine interface (HMI) graphics in order to visually present the model data to the operations in an easily understandable format.

The resulting integrated model for the acid gas injection system is configured to routinely update itself based on inputs from the process gas chromatograph analyser. The updated simulation results are then overlaid against actual process conditions to determine the process pathway in relation to the model calculated hydrate and phase envelope curves. The results are displayed graphically on the HMI in order to provide the operator with a tool to interpret the process data. The phase envelope HMI graphic developed is shown in Figure 6. Based on this interface, the plant operators can determine the optimal interstage temperature control points for the compressor.

For metering purposes, the integrated model is also used to calculate suitable density/compressibility inputs for the flow calculations based on actual measured process data. To provide a summary of the system, an overall acid gas injection process balance has been provided in an HMI screen, as shown in Figure 7. This allows the operator to monitor the flow through the system, as well as the effectiveness of the measurement balance, including accounting for the calculated water dropouts.

Conclusion

Overall, the VMG™ model integration with the DeltaV™ control system is a significant step forward in enhancing the operation of the Wembley plant's acid gas disposal scheme. For plant operations this combination provides a tool for both understanding and operating the system most effectively, and allows for proactive operation of the units based on a model based interpretation of incoming data.

The ultimate intent of the model integration with the DCS is to close the control loop and allow the model to determine the optimal control setpoint for the interstage coolers with limited operator intervention. In order to reach this point, further monitoring and testing will be required to determine the accuracy, robustness and performance of the entire system.

References

1. GAS PROCESSORS SUPPLIERS ASSOCIATION, Engineering Data Book, FPS, pp 21-7 (1998).
2. ROYAN, T. and WICHERT, E., Sulphur Disposal by Acid Gas Injection, SPE Paper 35585, presented at the Gas Technology Symposium, Calgary, Alberta, Canada, 28 April to 1 May (1996).
3. WICHERT, E., Acid Gas Compression and Injection, course notes, Sogapro Engineering Ltd, Calgary, Alberta. pp 4 - 11 (2002).
4. WICHERT, E., Acid Gas Compression and Injection, course notes, Sogapro Engineering Ltd, Calgary, Alberta. pp 5 - 6 (2002).
5. WICHERT, E., Acid Gas Compression and Injection, course notes, Sogapro Engineering Ltd, Calgary, Alberta. (2002).